



*Empower Your*  
**ALUMINIUM  
MACHINING**

Your technology partner for cost-effective machining

# SOLUTIONS AND INNOVATIONS 2025

# You

don't want to do everything differently. But many things better.

Opening up opportunities

# We

always find new ways to get more for you out of your processes.



## Interesting facts in brief on LinkedIn

Stay up to date about MAPAL and the latest technology.



<https://www.linkedin.com/company/mapal-dr-kress-kg>



# Contents

## ■ Empower Your Aluminium Machining

Engineering is the key _____	<b>04</b>
Challenges in aluminium machining _____	<b>06</b>
Aerospace - Hydraulic valve housing made of aluminium _____	<b>08</b>
Automotive - Precise scroll compressors for optimal thermal management _____	<b>10</b>
Automotive - Combined brake housing for autonomous driving _____	<b>12</b>
Fluid power - Smart tool combinations for pneumatic components _____	<b>14</b>

## ■ Product Innovations 2025

New connection for quick tool changes _____	<b>16</b>
Spotfacing tool with microstop cage _____	<b>18</b>
FixReam 700 - Programme expansion for new materials _____	<b>20</b>
LAT "Performance Line" _____	<b>21</b>
OptiMill-Tro-Inox and OptiMill-Uni-HPC-Pocket - Additions to the solid carbide milling cutter range _____	<b>22</b>
UNIQ DReaM Chuck 4.5° - New lengths and connections _____	<b>23</b>



## Empower Your Aluminium Machining

### Engineering is the key

**For many years now, aluminium materials have been becoming more and more prevalent in many industries. This trend continues unabated. Thanks to decades of experience in designing, producing and applying tools for aluminium machining, MAPAL is a leading technology partner for machining aluminium components.**

Aluminium and aluminium alloys are in principle easy to machine. As the cutting forces are low, high cutting data and in particular long tool life can be achieved with appropriate process planning. However, aluminium alloys have some special features which must be mastered. The geometry of the component and ever-increasing demands on tolerances and process capability pose additional challenges when machining aluminium.

MAPAL has an extensive product and application portfolio at its disposal thanks to many years of experience and countless proven solutions in the field of aluminium machining which includes both bore machining and milling applications.

The product range and extensive manufacturing expertise form the basis for optimal machining processes for aluminium parts. But the tool itself is not the only factor. Only through customised engineering can the wide-ranging product and application portfolio provide the perfect solution. And this is where MAPAL's true strength lies. Considerable experience developing new solutions time and again for the production of aluminium parts make the tool manufacture a first-class solution provider in this area.

According to the MAPAL philosophy, the perfect solution can only be one that is precisely tailored to the needs and requirements of the customer. The expectation is not over-engineering but rather machining processes designed based on requirements. MAPAL sees itself as a solution provider and technology partner and, as opposed to a conventional tool supplier, does not only consider technical aspects but also tries to put itself in the customers' shoes. This customer-centred focus is behind the "Basic - Performance - Expert" solution approach and enables MAPAL to tailor the tools to the customers' requirements.

# Focus on the customer

Comprehensive market knowledge in the automotive, aerospace, fluid power and die & mould focus segments enables a deep understanding of the specific components and their manufacturing processes. Combined with extensive materials expertise, this knowledge allows MAPAL to create tailor-made solutions from a diverse product portfolio - similar to a modular system. This integrative process, which takes into account market requirements, component geometries, machine and process as well as economic aspects, is the key to successful engineering. The customer is always the focus of all activities.

## CUSTOMER REQUIREMENTS

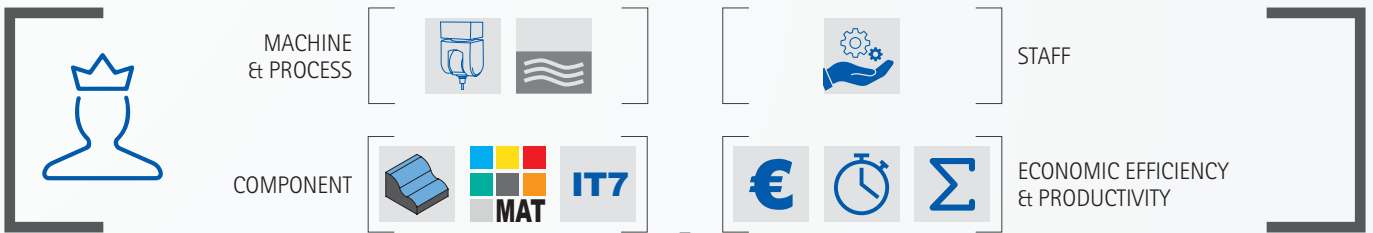

## MAPAL ENGINEERING COMPETENCE

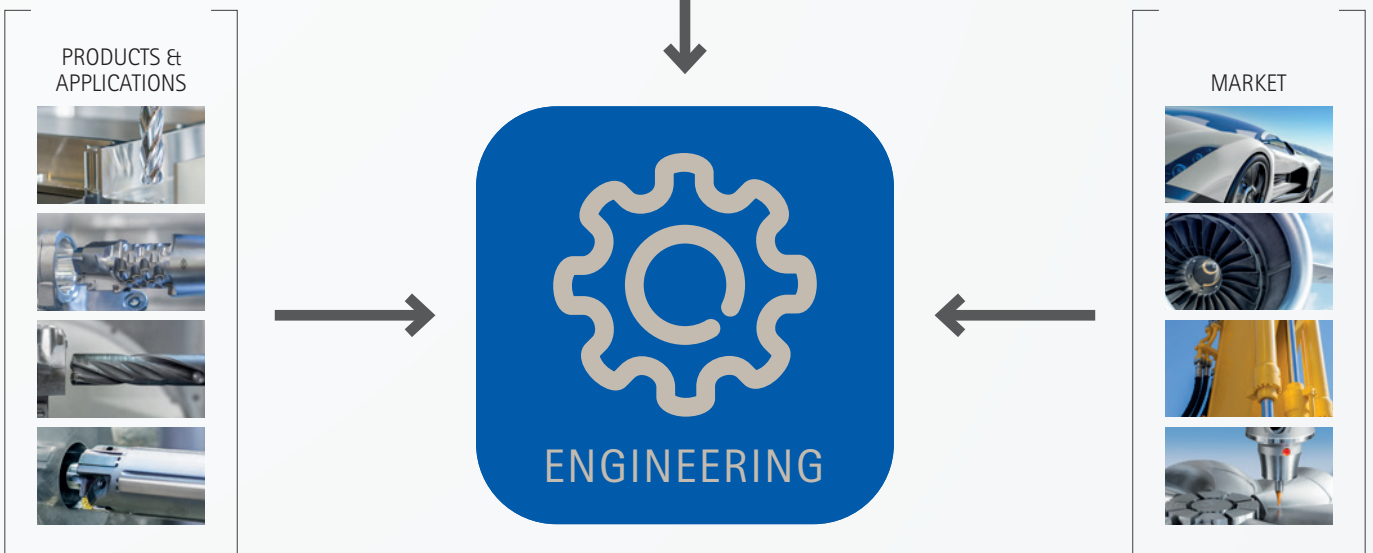

## CUSTOMISED SOLUTION

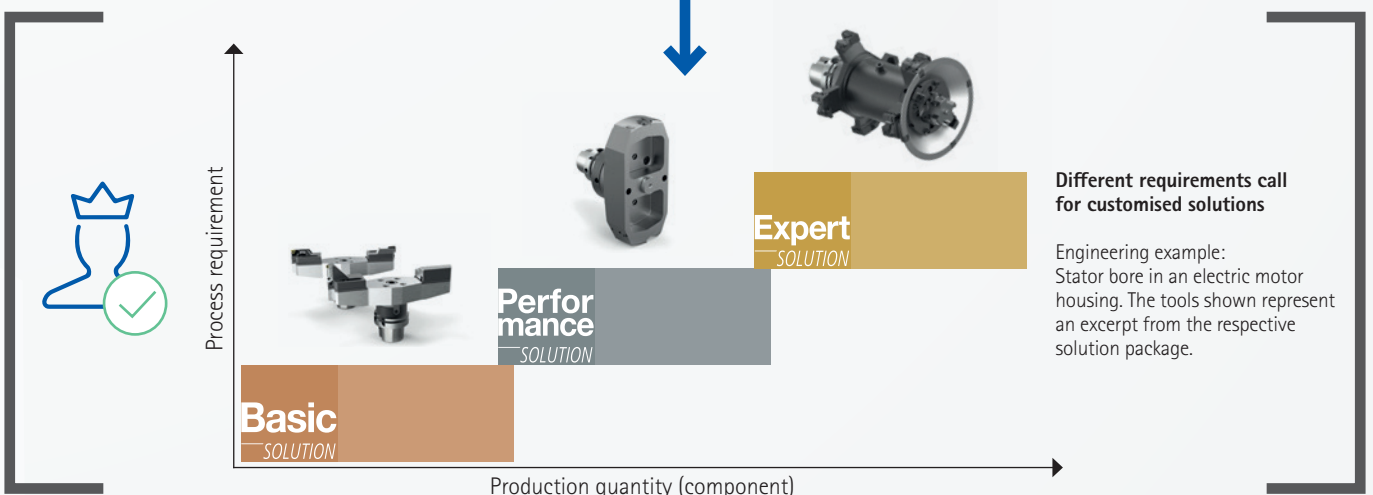

# Challenges in aluminium machining

# MILLING

### HIGHLY PRECISE AND DEFINED SURFACES AND SHAPES

Face milling systems with carbide and PCD as well as radius and form milling cutters guarantee precise surfaces and contours, even on free-form surfaces.

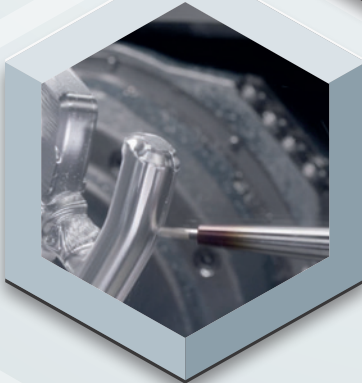

### COMPLICATED PROCESS REQUIREMENTS

Milling cutter arbors and customised tool systems with vibration damping ensure reliable machining results under difficult conditions.

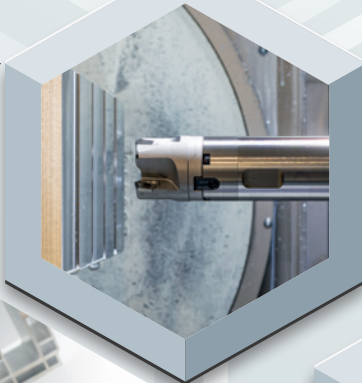

### HIGH VOLUME MILLING

Milling systems with a highly positive rake angle and large, polished chip spaces maximise the material removal rate with low cutting forces and high surface quality.

### FLEXIBILITY WITHOUT COMPROMISE

Solid carbide milling cutters with innovative face geometry and large chip flutes enable universal milling, ramping and drilling with one tool.

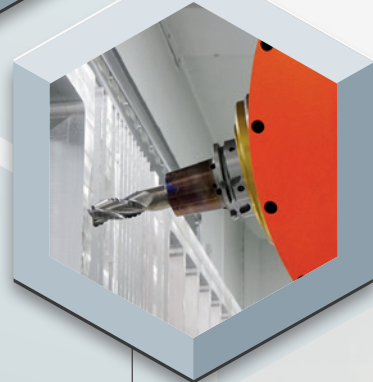
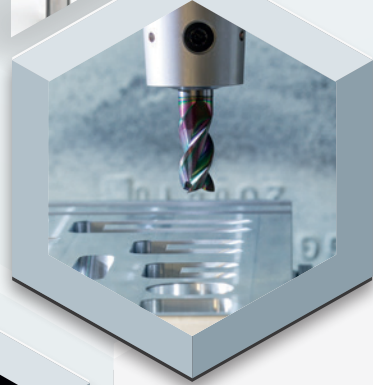

# BORE MACHINING

## HIGHEST PRODUCTIVITY IN SERIAL PRODUCTION

Multi-bladed solid carbide tools, replaceable drilling heads and combination tools increase productivity in serial production.



## Empower Your ALUMINIUM MACHINING

## REDUCED BURR FORMATION WHEN MACHINING BORES

Milling instead of drilling and drills with countersink minimise burrs and enable machining in a single step.

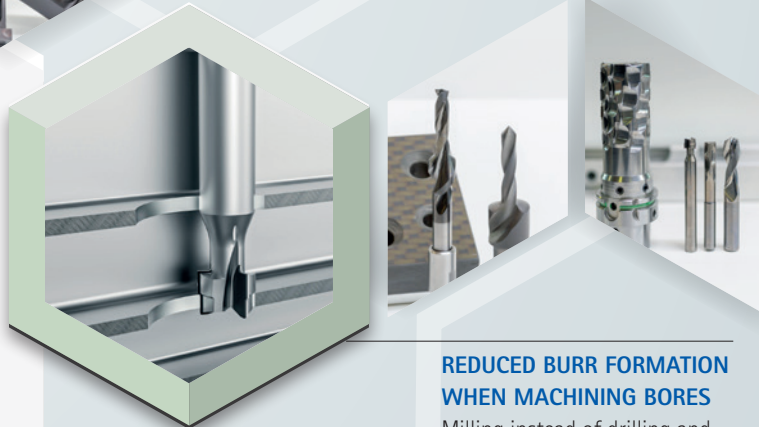

## DEFINED CHIP BREAKING AND CONTROL

Inserts with chip breaking geometries, highly positive cutting edges and indexable drilling inserts provide short, controlled chips.



## PROCESS RELIABILITY WHEN DRILLING DEEP BORES

Matched pilot and deep drilling tools of solid carbide as well as with PCD ensure reliable machining of deep bores.





## High requirements for safe control

### Hydraulic valve housing made of aluminium

When something needs to be moved on an aircraft, valve bodies in various designs use hydraulics to control important functions such as flaps and landing gear. These housings vary in size and shape, but the machining requirements remain similar.

MAPAL uses a sample component designed on the basis of real requirements, the "Generic Component", to reproduce all machining steps

from pre-machining to finishing. The Generic Component was not designed as a replica of a specific customer component, but is based on the machining requirements of various real components. The accumulated knowledge from global experience within the MAPAL Group has been integrated into this sample component.

On this basis, MAPAL is able to identify suitable machining strategies and cutting values. However, as several different solutions are often feasible to solve the requirements, the optimum machining strategy is finally put together with the customer.

The requirements in the aerospace sector are particularly high, as valve housings are often very complex. Production often has to deal with difficult process conditions and the challenges of defined chip breaking and chip control. Deep bores with cross bores or grooves result in interrupted cuts. In addition, the low silicon content of the aluminium used poses the challenge of reliably breaking the very long chips.

With the Generic Component for Aerospace, MAPAL is continuing a successful concept from the automotive sector to show several options for solving problems. The decisive factor is which solution offers the greatest benefits to the specific customer.







Empower Your  
**ALUMINIUM  
MACHINING**

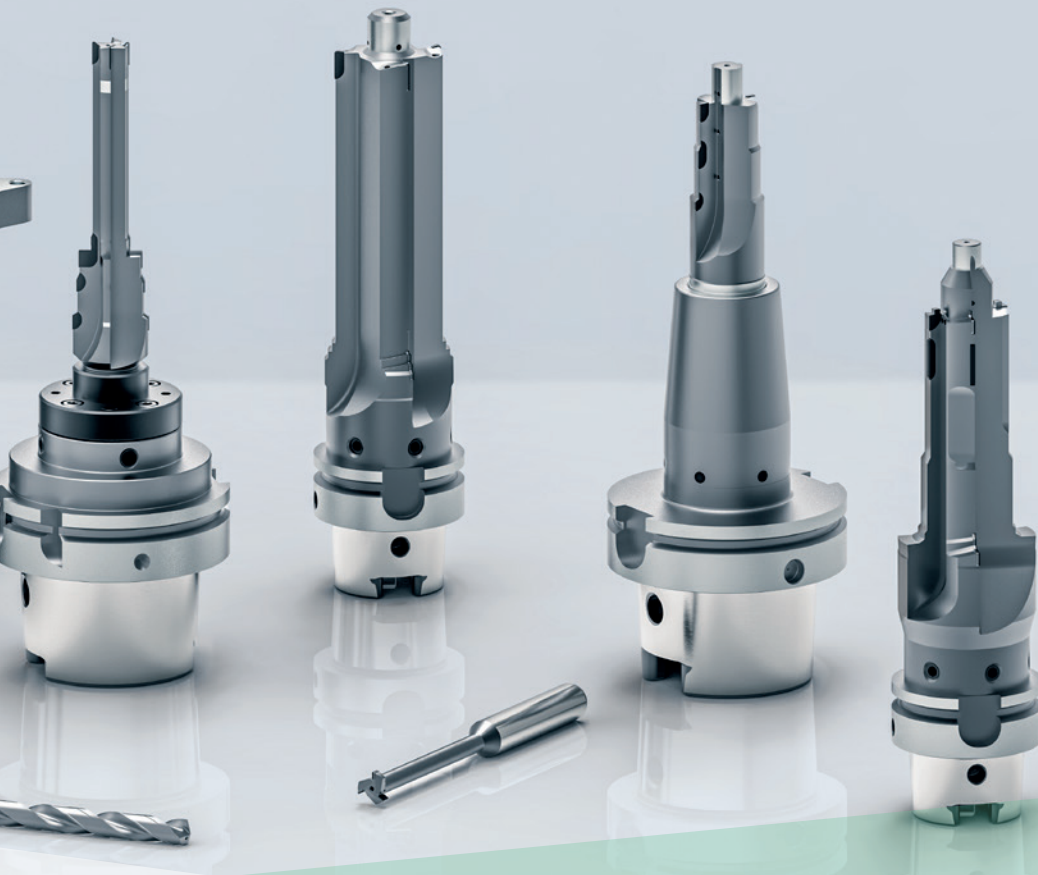

### COMPONENT EXPERTISE

**Segment:** Aerospace

**Component:** Hydraulic valve housing

**Challenge:** Defined chip breaking and chip control

### Component features

- Aluminium with low silicon content
- High demands on shape and position tolerances
- High surface quality
- Deep bores with cross bores or grooves

### Machining requirements

- Short chips
- Reliable chip breaking
- Interrupted cut

### Machining highlights

- PCD circular milling cutters reduce cutting forces, minimise vibrations and produce short chips.
- Tools with PCD guide pads or long cutting edges ensure that the tool is guided safely, even with cross bores or grooves.
- Reliable chip removal thanks to tools with large and polished chip flutes and additional chip breakers on the cutting edges.





## Precise scroll compressors for optimal thermal management

### High degree of precision in mass production

The global automotive market will continue to develop in the coming years, with the biggest growth taking place in the realm of electric vehicles. As the share of hybrid and battery-powered cars grows, so does the share of vehicles with scroll compressors.

MAPAL has defined the scroll compressor as a focus component in the field of electromobility. It has very high demands with respect to the machining quality and is required in large quantities. With specifications that are sometimes less than 20 µm, the form of the scroll spirals and their perpendicularity have very tight tolerances. A surface finish with an average roughness depth in the single micrometre range is required for the flawless functionality of both spirals in relation to one another. The machining process to manufacture the scrolls involves milling the surfaces of the spiral shapes as well as the top and base surfaces. The pre-machining process already comes very close to the final contour.

A step milling cutter provides the finish for the face surface and spiral shapes during the fine machining that follows. In a single step, the tool moves inwards, turns around at the innermost point with the smallest radius, and then moves outwards again along the other side of the spiral shape. Special radii and transitions between the face surface and spiral call for extremely precise contours on the milling tool.





## COMPONENT EXPERTISE

**Segment:** Automotive  
**Component:** Scroll compressors  
**Challenge:** Complicated process requirements

### Component features

- High degree of shape accuracy of the spirals ( $\leq 20 \mu\text{m}$ )
- High perpendicularity of flanks to base surface ( $\leq 20 \mu\text{m}$ )
- Parallel alignment and flatness of  $\leq 10 \mu\text{m}$
- Surface roughness (Rz) in the single-digit micrometer range

### Machining highlights

- Pre-milling of spiral forms with a high degree of accuracy for final contours.
- Step milling cutter for finishing flat surfaces and spiral shapes.
- Special radii and transitions between the flat surface and spiral require very precise contours on the milling tool.

### Machining requirements

- Reliable chip removal
- Burr-free machining
- Small amount of heat produced at the cutting edge
- Low spindle power (BT30)

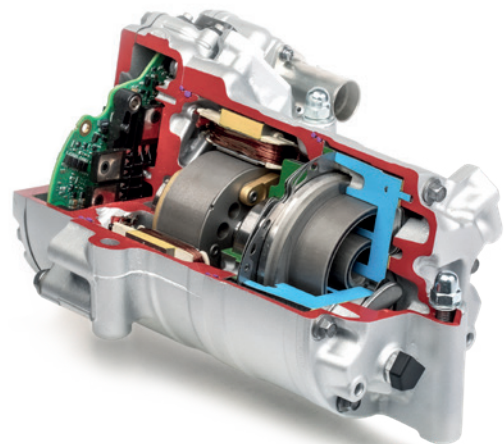



## Combined brake housing for autonomous driving

### A technically sophisticated combination

A combined brake housing unites the main brake cylinder, brake booster and ABS/ESP in a single part. This component smooths the way for self-driving cars and saves weight. Aluminium with a low silicon content of less than 1% is the material of choice. Long chips are produced during machining due to the fibre direction and the low silicon content.

To ensure excellent chip breaking when boring and reaming using PCD cutting edges, MAPAL makes use of application-specific chip-breaking geometries. Their special topology ensures defined chip breaking and thus short chips, even at low feed rates and machining allowances. This enables maximum performance and process reliability.

Tight tolerances and high surface finish requirements apply to every bore. The surfaces must be free of scoring, which can be caused by chips or vibration during machining. Some bores are subsequently anodised to provide more resistance to wear. An average roughness depth  $Rz = 1 \mu\text{m}$  is required to hold this coating.

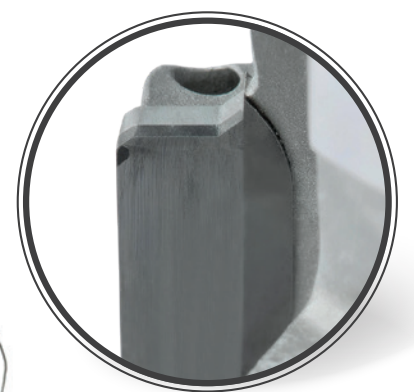

PCD cutting edge with chip-breaking geometry



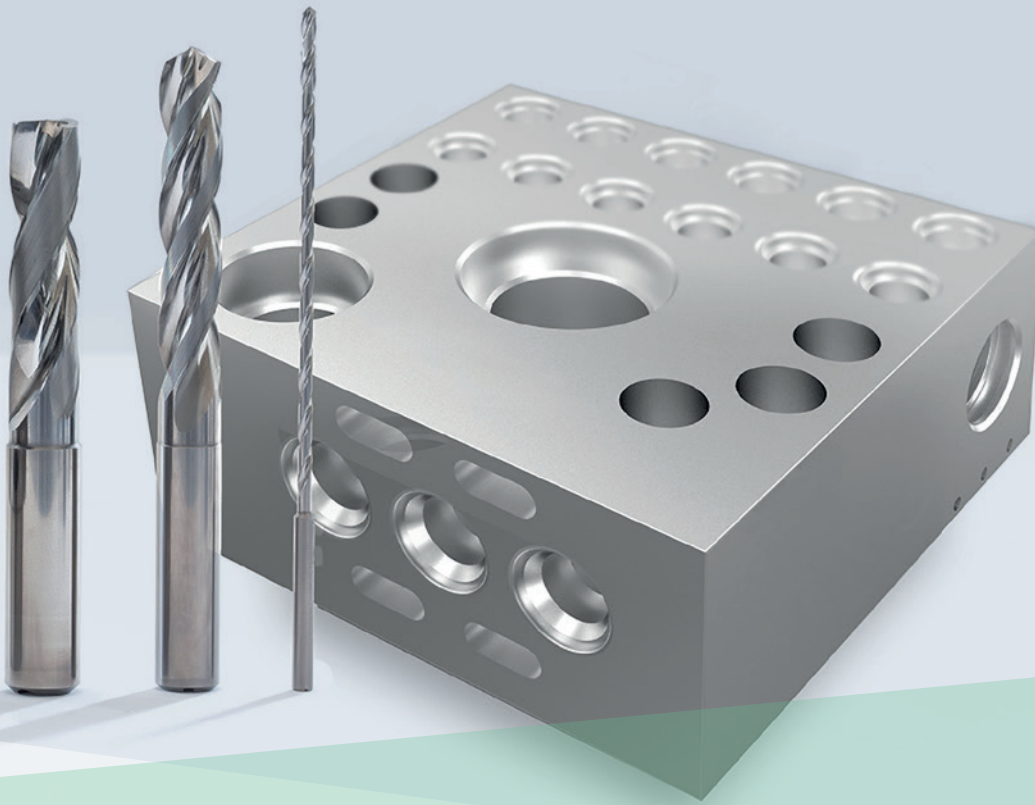

### Component features

- Extruded aluminium with low silicon content (< Si1)
- High quantities
- Surface finish Ra < 3 µm
- High process reliability with regard to tolerance requirement and surface finish

### Machining requirements

- Short chips
- Reliable chip breaking process
- Multi-spindle machining

### Machining highlights

- Special carbide step drill for pre-machining the valve bore.
- PCD tools with multiple cutting edges achieve the desired surface quality.
- Circular milling cutters produce the different contours of the valve bores with very high contour accuracy.
- Various deep bores, which interlock in the component, are drilled using spiral tools with machining depths of up to 30xD. Reliable chip removal process and high level of productivity are guaranteed.

### COMPONENT EXPERTISE

**Segment:** Automotive

**Component:** Combined brake housing

**Challenge:** Defined chip breaking and control



## Smart tool combinations for pneumatic components

### Spool bores for pneumatic valve housing in focus

Forces and movement are produced, controlled and efficiently transferred in pneumatics via air and gas. This takes place in valves and cylinders for the most part. Areas of application include general machining, logistics and medical technology.

MAPAL has designed economical and high-precision machining processes for two focus components in the form of a housing for pneumatic valves and a pneumatic cylinder. It was able to draw on its expertise and product portfolio for aluminium machining here.

The components are made of aluminium material with a small amount of silicon, which places high demands on the machining solution with respect to chip formation and removal.

Particular attention is paid to avoiding burr formation or scoring: Burrs on the bores can significantly affect the function of a valve or even lead to it malfunctioning. The cost driver in the production of valve housing is the spool bore, where tight surface, form and position tolerances must be precisely adhered to. MAPAL concentrates on providing customers with the most economical solution for their machining by means of tool combinations.

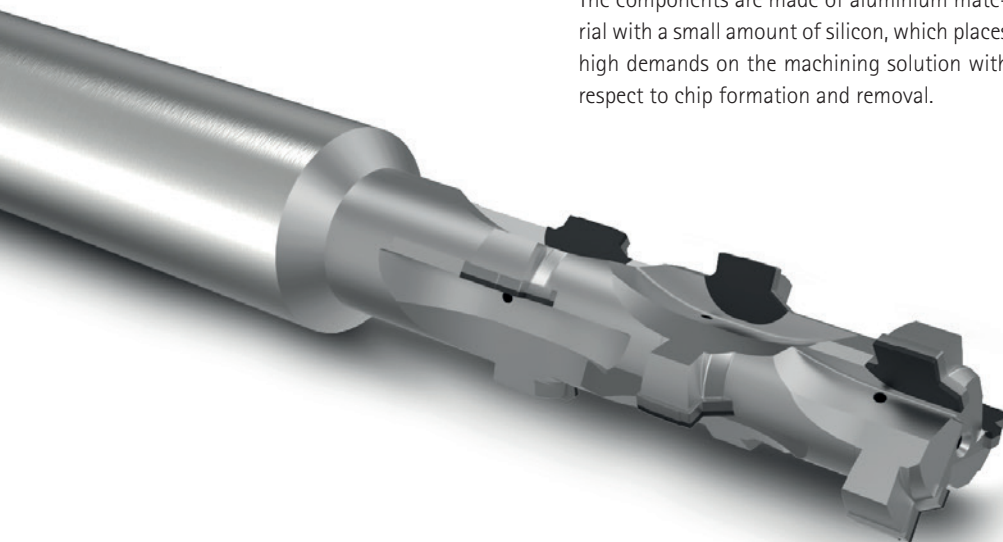



Empower Your  
**ALUMINIUM  
MACHINING**



### Component features

- Aluminium with low silicon content
- Surfaces free of burrs and score marks
- Tight surface, form and position tolerances (roughness  $R_z = 1 \mu\text{m}$ )
- Very high quantities

### Machining requirements

- High cycle time requirements
- High demand for process reliability
- Machining with fewest possible burrs and score marks

### Machining highlights

- Ideal chip breaking due to special cutting geometry.
- Perfect surfaces and contact ratios due to high-quality PCD finish tools ( $R_z = 1 \mu\text{m}$ ).
- Combination tools for optimal process design and cycle time reduction.

### COMPONENT EXPERTISE

**Segment:** Fluid power

**Component:** Pneumatic valve housing

**Challenge:** Reduced burr formation when machining bores

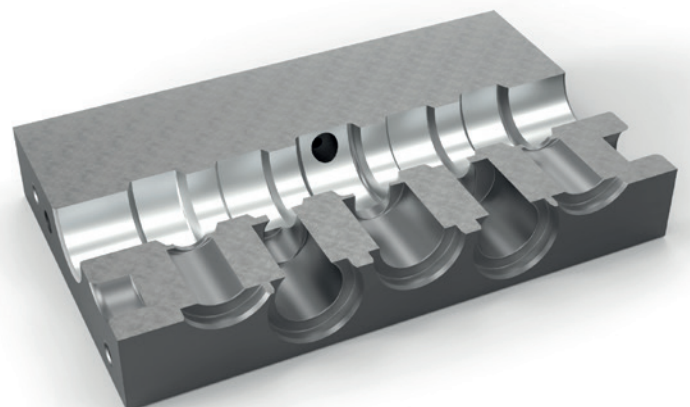



## New connection for quick tool changes

### Quicker and easier handling with greater stability

MAPAL has developed a new connection for replaceable head milling systems that makes tool changes quicker and easier. The interchangeable head is simply inserted, rotated 90 degrees and immediately locked in place, which is significantly more straightforward compared to traditional thread-based systems. The new BFS-system (Bayonet Fitting System) offers a very high stability and symmetrical force distribution, which increases tool life and machining quality.

The new replaceable head holders with extended cooling channels allow more efficient cooling directly at the cutting edges and much greater stability. The new tool holders provide process reliability even at high temperatures. With this connection, material consumption at the connection is reduced by around 70 per cent compared to previous connections.





4



70 per cent material savings at the connection compared to the MAPAL CFS connection

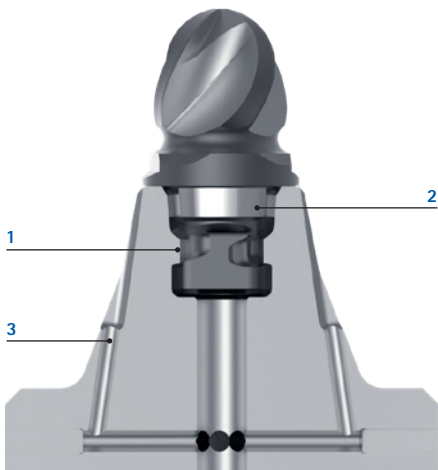

#### 1 90° locking mechanism

- Quick and easy tool change

#### 2 High stiffness

- Long tool life and high machining quality

#### 3 Extended cooling channels

- More efficient cooling, longer tool life

#### 4 Saving resources

- By saving material at the connection





## Spotfacing tool with microstop cage

**For spotfacing, countersinking, chamfering and deburring during aircraft assembly**

To protect aircraft from lightning strikes, all parts must be connected to each other in an electrically conductive way. This necessitates removing the paint in the bore area during assembly. MAPAL has developed an innovative spotfacing tool with a patent-pending microstop cage that removes the paint efficiently and is particularly user-friendly in a plug-and-play solution.

The new tool replaces the previously used brushes and offers numerous advantages. It stops the surface from getting scratched and being penetrated too deeply, minimises operator errors and is easy to maintain. The tool rotates within the cage and only protrudes out as far as the material is to be removed, ensuring precise machining. The innovative tool system is extremely versatile and is also suitable for countersinking, chamfering and deburring applications.

The spotfacing tools are available with microstop cages in two cutting depths for standard coating thicknesses. The microstop cages are available in different colours to ensure error-free application.

An extraction system can also be fitted to the tool to comply with environmental regulations and to avoid harmful chromate dust.





Advantages

- Plug-and-play solution
- No scratches on the paint surface
- High level of process stability
- No facets visible
- Additional extraction possible
- Can be reground



Countersinking



Counterboring

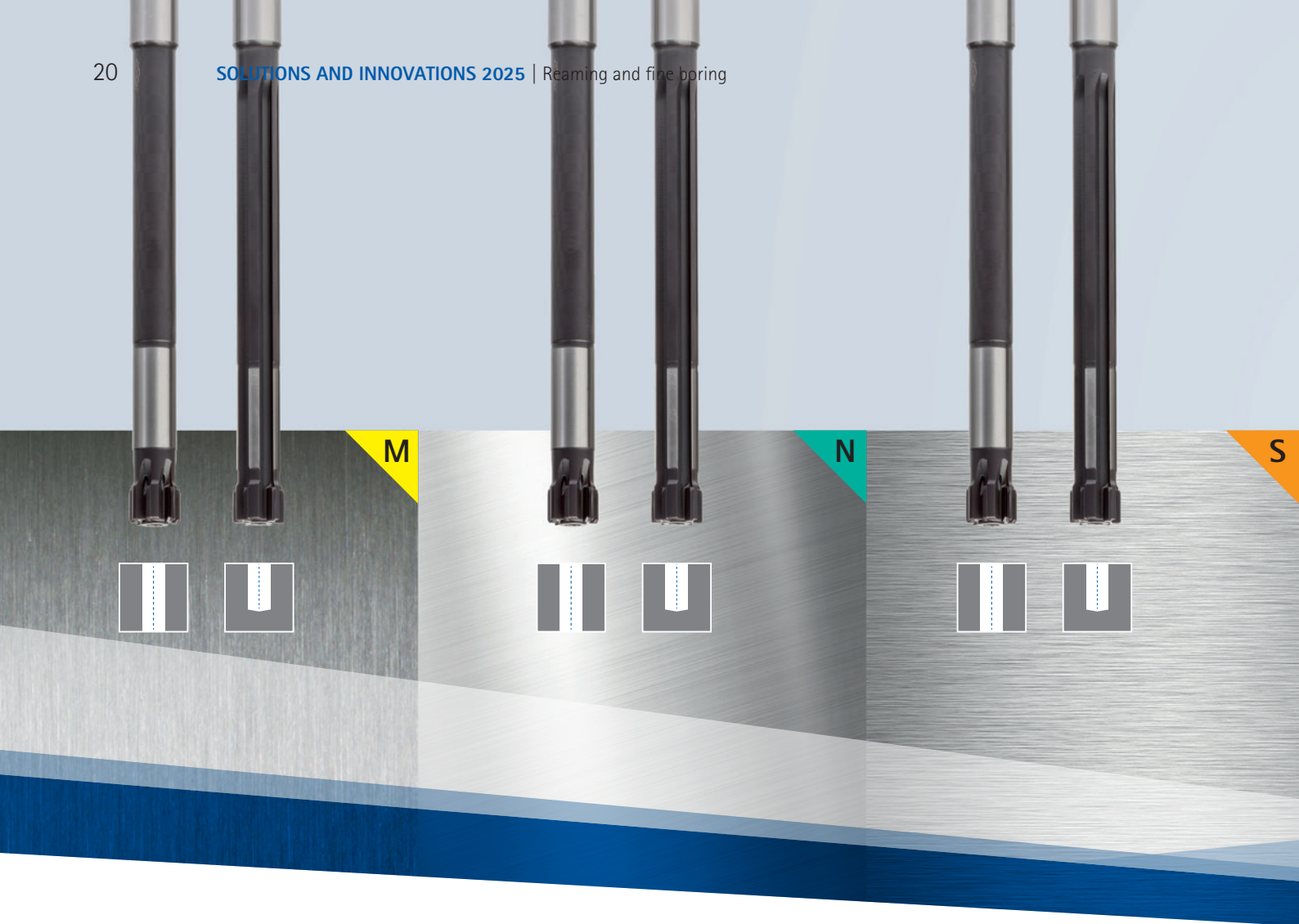

## FixReam 700

Expansion of the range to include materials in the **M N S** machining groups

The application scope for the FixReam 700 family presented in 2023 is expanded to include additional machining groups. The high-performance reamers are the first choice when high cutting data and short machining times are required. The high level of reusability achieved by regrinding and replacing the cutting edges makes the

FixReam 700 a particularly sustainable tool. The high-performance reamer can be reground twice before new cutting edges have to be brazed. The programme expansion includes new cutting materials with PVD coating and leads that have been specially developed for use in stainless steels, non-ferrous metals and difficult-to-machine materials. New designs with coatings for steel and cast iron are also available. The reamers are available in short or long designs for through bores and blind bores and can be configured in diameters ranging from 9.9 to 32.2 mm.

### 1 PVD coating

- High level of hardness and resistance to wear

### 2 Optimal chip formation

- Thanks to new, innovative leads

### 3 Expansion screw for compensation

- Allows up to nine tool lives

### 4 Patented geometry

- 30 % better roundness and cylindrical form





## LAT "Performance Line"

### Standardised facing heads for the highest demands

Facing heads are used for turning operations on machines with cross feed devices, especially rotary transfer machines. This is where recesses, face surfaces and internal and external contours are machined, primarily in large series production. Standardised facing heads from MAPAL are equipped with an individual mounting tool and can handle a wide range of turning operations using the NC-controlled cross feed devices.

The new, standardised facing heads from the "Performance Line" are available from stock in single- and double-slide versions and are offered with or without internal cooling. The available diameters are 100 mm, 125 mm and 160 mm with a transverse stroke of up to 30 mm. Special adaptations to customer interfaces are possible on request. The standardised connection can also be used flexibly with existing machines and mounting tools at the customer's site.

All components have been optimised for maximum service life and the highest level of precision – and can even be used in difficult conditions.

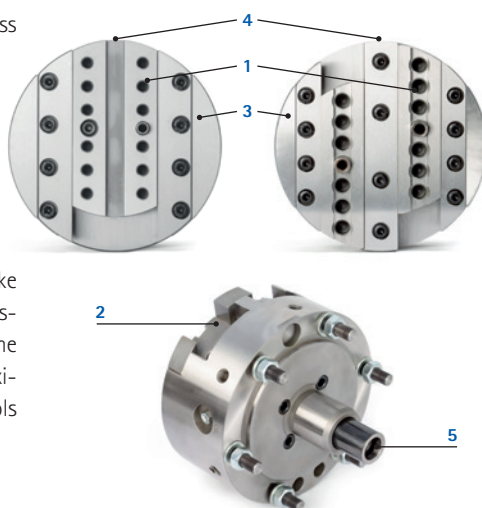

#### 1 Compatibility

- Standardised connections for maximum flexibility in all possible applications

#### 2 Performance

- Moving parts designed to reduce weight

#### 3 Stability

- Maximum support of the moving parts in the tool body
- Stable design of all guides and connections

#### 4 Availability

- Available in a single-slide or double-slide design, with and without internal cooling

#### 5 Sturdiness

- Maximum wear resistance and process reliability thanks to specially coated drawbar

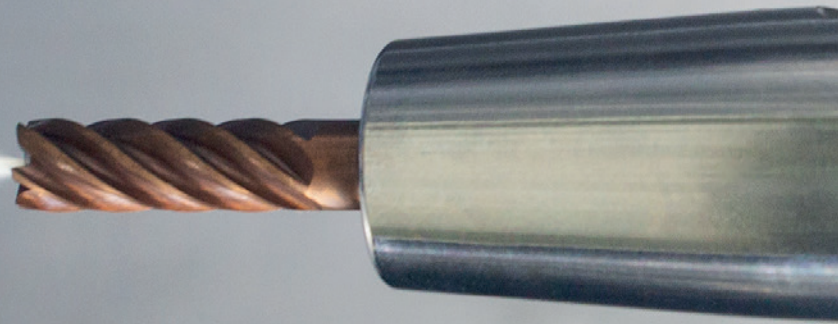

## OptiMill®-Tro-Inox and OptiMill®-Uni-HPC-Pocket

### Programme expansions to the solid carbide milling cutter range

The OptiMill-Tro-Inox trochoidal milling cutter has been specially designed for applications with problematic chip removal. Especially for small pockets, pocket corners or difficult component contours, a new, central cooling channel ensures reliable chip removal thanks to its high cooling and flushing capacity. The solid carbide milling cutter is available in diameters ranging from 6 to 20 mm.

The OptiMill-Uni-HPC-Pocket in 3xD has been developed to optimise time-consuming ramping processes when machining pockets. With a patented plunge face, the milling cutter can be plunged at angles of up to 45°. The arrangement of the chip breakers ensures straightforward chip removal. The OptiMill-Uni-HPC-Pocket in 3xD is available in diameters ranging from 5 to 20 mm.



#### OptiMill-Tro-Inox

##### 1 Central internal cooling

- Excellent cooling and flushing performance for reliable chip removal

##### 2 Cutting length 3xD

- Suitable for a wide range of trochoidal machining operations

#### OptiMill-Uni-HPC-Pocket

##### 3 Cutting length 3xD

- Suitable for deep pockets or grooves

##### 4 Three chip breakers per cutting edge

- Short chips and improved chip removal

##### 5 Plunge face with drill tip

- Ramps of up to 45° possible
- Suitable for groove milling

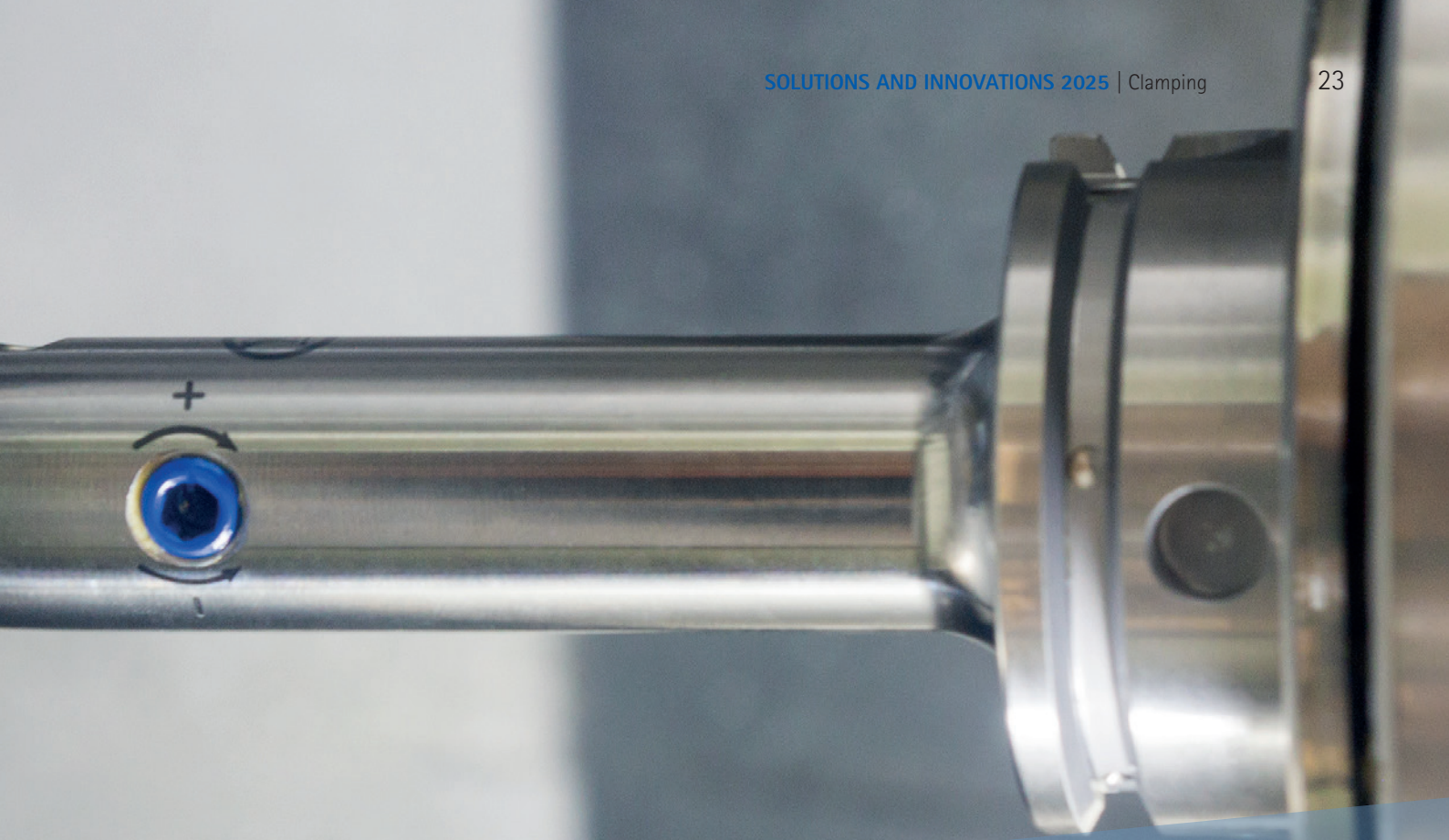

UNIQ® the triple award-winning chuck from MAPAL



## UNIQ® DReaM Chuck 4.5°

### New lengths added to range

To meet customer requirements and continue to support the changeover from shrink chucks to the hydraulic expansion technology, the range of UNIQ DReaM Chuck 4.5° for reaming and drilling applications and for use with finishing cutters has been expanded to now include new lengths and connections.

With the UNIQ DReaM Chucks, MAPAL is the first supplier in the world to offer hydraulic chucks with the original heat shrink contour according to DIN 69882-8 in 160 mm for HSK-A63 and HSK-A100. This means that hydraulic chucks can also be used in deep grooves with critical tool restrictions.

#### Available designs

#### UNIQ DReaM Chuck 4.5°

- **NEW since May 2024:** HSK-A100 and BT40, 120 mm available from stock (ø 6 – 20 mm)
- **NEW from September 2024:** HSK-A63 and HSK-A100, 160 mm available from stock (ø 6 – 32 mm)





Discover tool and service solutions now that give you a lead:

## BORE MACHINING

REAMING | FINE BORING

DRILLING FROM SOLID | BORING | COUNTERSINKING

MILLING

CLAMPING

TURNING

ACTUATING

SETTING | MEASURING | DISPENSING

SERVICES

FOLLOW US

